

EMITTER GUARD KIT

Models: CB20 through CB50

The emitter guard kit is required when the CB series of infrared tube heaters is installed at mounting heights between 6 ft. and 8 ft. above a finished floor. For installations above 8 ft., the emitter guard kit is not required but may be used for decorative purposes as desired.

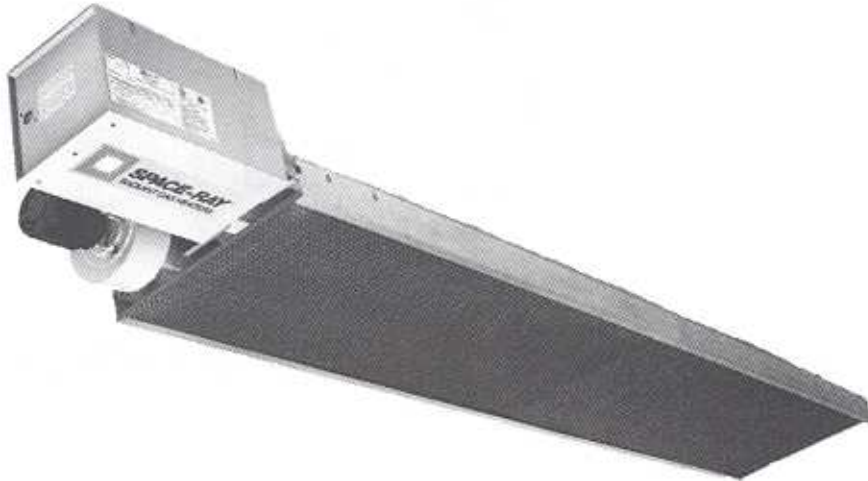

INSTALLATION INSTRUCTIONS:

1. Place the center hanger bracket on the heater as shown below using the U-bolts and hardware supplied in this kit. NOTE: Spacing between each hanger bracket should be as shown. See Figure 1.
2. Pre-assemble two (2) emitter guard holder panels for each side of the heater using the center panel joiner and screws provided in the kit. See Detail A.

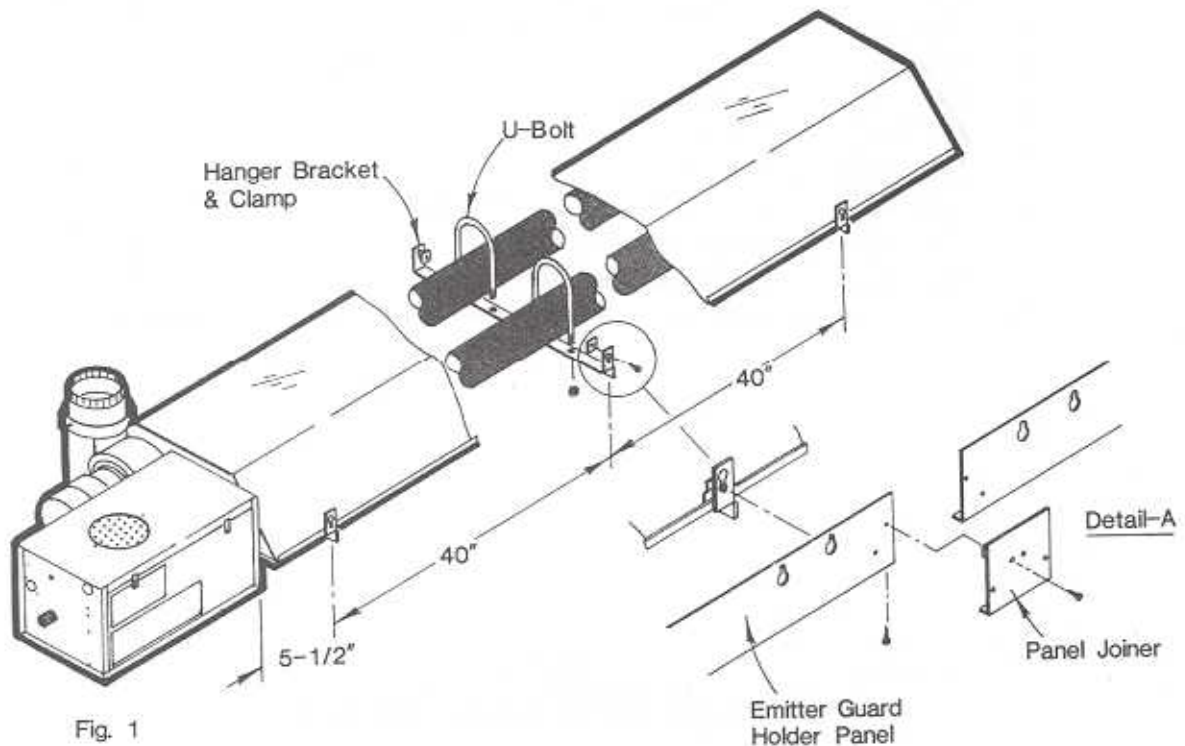

3. Loosen the clamp screws or each hanger bracket clamp.
4. Align the slots of the pre-assembled holder panels with the slots in the hanger brackets. Slip the slots over the screw heads of each clamp screw.
5. Tighten each clamp screw until the panels are securely in place.
6. Slide both sections of the emitter guard onto the holder panels from one end of the heater until they are flush with the heater reflector.

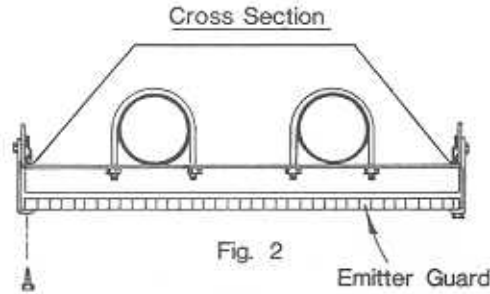

7. Insert screws into the bottom corners of each emitter guard holder panel. This will prevent the emitter guard from sliding. See Figure 2.

KIT NO. 4348500

PART NO.	DESCRIPTION	QTY
0212513	Machine Screw #10-24 x 1/2	2
0212711	Hex Nut 5/16-18	4
0221202	Sheet Metal Screw #8 x 1/2	16
3036605	Emitter Guard 18-1/4 x 48" Long	2
4276901	Hanger Clamp	2
4277000	U-bolt	2
4277300	Hanger Bracket	1
4350700	Emitter Guard Holder Panel	4
4350800	Center Panel Joiner	2
4350900	Form, Emitter Guard Kit	1